

\* THESE ARE TYPICAL STANDARDS WHICH MAY BE VARIED TO MATCH EXISTING FEATURES AT THE DISCRETION OF THE PLANNING STAFF.

1. CURB RADII SHALL BE 5' MEASURED TO BACK OF CURB.\*
2. DRIVEWAY APRON SHALL BE 6" THICK CONCRETE (MIN.).
3. ASPHALT SHALL BE SURFACE COURSE FOR ASPHALT DRIVEWAYS.
4. IF THERE IS NO SIDEWALK, THE DRIVEWAY APRON SHALL BE 6' AS MEASURED PERPENDICULAR FROM BACK OF CURB OR EDGE OF PAVEMENT.
5. EXPANSION JOINTS SHALL BE A MINIMUM OF 1/2" AND EXTEND THE FULL DEPTH OF THE CONCRETE. EXPANSION JOINT MATERIAL SHALL MEET AASHTO M213 FOR AN ASPHALTIC FIBER EXPANSION JOINT MATERIAL AND INSTALLED WITH A ZIP STRIP WHICH IS REMOVED AFTER THE CONCRETE HAS CURED AND SEALED WITH A MASTIC SEALER. OTHER ALLOWABLE EXPANSION JOINT MATERIAL ARE 1"x6" OR 2"x6" PRESSURE TREATED PINE, REDWOOD OR WESTERN RED CEDAR WITH NAILS DRIVEN THROUGH EACH SIDE TO PREVENT THE BOARD FROM BEING PUSHED OUT OF THE JOINT.
6. CONTRACTION JOINTS TO BE PLACED IN CONCRETE DRIVEWAY SO THAT NO SLAB DIMENSION IS MORE THAN 15'.
7. ALL SIDEWALKS AND DRIVEWAYS TO RECEIVE A BROOM FINISH.
8. CITY SHALL INSPECT ALL SIDEWALKS AND DRIVEWAYS IN PUBLIC RIGHT OF WAY PRIOR TO CONCRETE OR ASPHALT PLACEMENT. PROVIDE 24 HOURS NOTICE PRIOR TO PLACEMENT.
9. ALL CONCRETE FOR CURB, SIDEWALKS AND DRIVEWAYS SHALL BE CLASS B CONCRETE PER CITY SPECIFICATIONS (3500 PSI, 4-7% AIR ENTRAINED). CONCRETE MAY NOT BE POURED IF A FALLING AIR TEMPERATURE FALLS BELOW 40° F NOR RESUMED UNTIL AN ASCENDING AIR TEMPERATURE RISES ABOVE 35° F WITHOUT SPECIFIC AUTHORITY FROM THE CITY REPRESENTATIVE.
10. DRIVEWAY APRON AND MODIFIED CURB SHALL BE POURED MONOLITHICALLY.
11. REFER TO STREET DESIGN CRITERIA FOR SIDEWALK AND GREENSPACE WIDTHS.

GUTTERLINE (IF SAWCUT FOR DRIVEWAY INSTALLATION, THEN SEAL OVER-CUT AREAS AS SHOWN USING DETAIL BELOW.)  
 MODIFIED CURB  
 IF NECESSARY TO REMOVE EXISTING CURB, A FULL DEPTH SAWCUT SHALL BE MADE AT CURB AND STREET PAVING JOINT. ANY DAMAGE TO THE STREET SHALL BE REPAIRED AT CONTRACTOR'S EXPENSE.

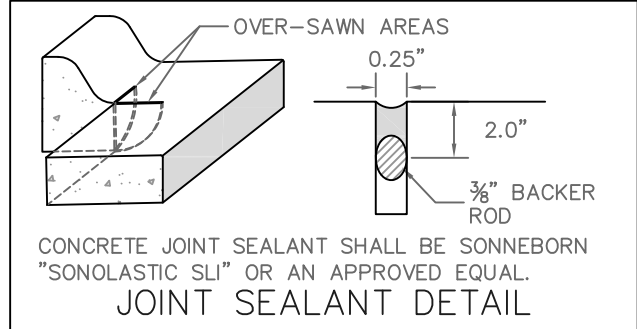
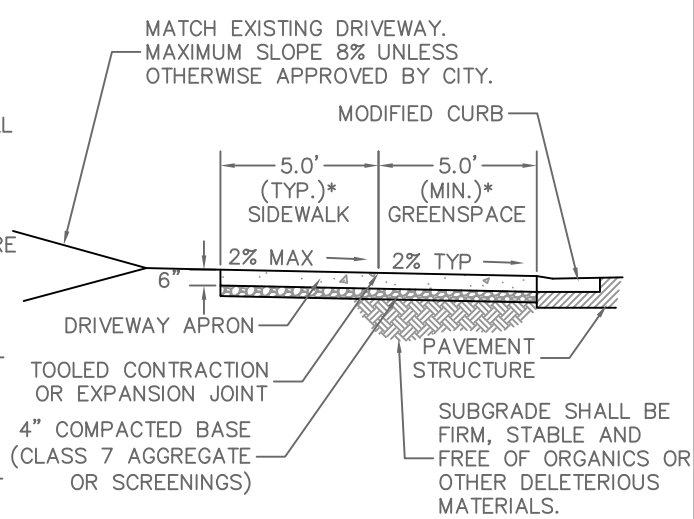

**CITY OF ROGERS**  
 301 WEST CHESTNUT STREET  
 ROGERS, ARKANSAS 72756  
 (479) 621-1186

# RESIDENTIAL DRIVEWAY DETAIL

NOT TO SCALE

FEBRUARY 15, 2012